



Santos Cheese Grater
Model Santos 02
Item 40619
Instruction Manual



Revised - 09/02/2021



Toll Free: 1-800-465-0234
Fax: 905-607-0234
Email: service@omcan.com
www.omcan.com

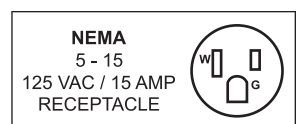

Table of Contents

Model Santos 02

Section	Page
General Information -----	3 - 4
Safety and Warranty -----	4 - 6
Technical Specifications -----	6
Operation -----	6 - 8
Maintenance -----	8 - 9
Troubleshooting -----	9
Figure Drawings -----	9 - 10
Parts Breakdown -----	11 - 13
Electrical Schematics -----	14
Warranty Registration -----	15



General Information

Omcan Manufacturing and Distributing Company Inc., Food Machinery of America, Inc. dba Omcan and Omcan Inc. are not responsible for any harm or injury caused due to any person's improper or negligent use of this equipment. The product shall only be operated by someone over the age of 18, of sound mind, and not under the influence of any drugs or alcohol, who has been trained in the correct operation of this machine, and is wearing authorized, proper safety clothing. Any modification to the machine voids any warranty, and may cause harm to individuals using the machine or in the vicinity of the machine while in operation.

CHECK PACKAGE UPON ARRIVAL

Upon receipt of an Omcan shipment please inspect for external damage. If no damage is evident on the external packaging, open carton to ensure all ordered items are within the box, and there is no concealed damage to the machine. If the package has suffered rough handling, bumps or damage (visible or concealed), please note it on the bill of lading before accepting the delivery and contact Omcan within 24 hours, so we may initiate a claim with the carrier. A detailed report on the extent of the damage caused to the machine must be filled out within three days, from the delivery date shown in the shipping documents. Omcan has no recourse for damaged products that were shipped collect or third party.

Before operating any equipment, always read and familiarize yourself with all operation and safety instructions.

Omcan would like to thank you for purchasing this machine. It's of the utmost importance to save these instructions for future reference. Also save the original box and packaging for shipping the equipment if servicing or returning of the machine is required.

Omcan Fabrication et distribution Compañie Limité et Food Machinery d'Amérique, dba Omcan et Omcan Inc. ne sont pas responsables de tout dommage ou blessure causé du fait que toute personne ait utilisé cet équipement de façon irrégulière. Le produit ne doit être exploité que par quelqu'un de plus de 18 ans, saine d'esprit, et pas sous l'influence d'une drogue ou d'alcool, qui a été formé pour utiliser cette machine correctement, et est vêtu de vêtements de sécurité approprié. Toute modification de la machine annule toute garantie, et peut causer un préjudice à des personnes utilisant la machine ou des personnes à proximité de la machine pendant son fonctionnement.

VÉRIFIEZ LE COLIS DÈS RÉCEPTION

Dès réception d'une expédition d'Omcan veuillez inspecter pour dommages externes. Si aucun dommage n'est visible sur l'emballage externe, ouvrez le carton afin de s'assurer que tous les éléments commandés sont dans la boîte, et il n'y a aucun dommage dissimulé à la machine. Si le colis n'a subi aucune mauvaises manipulations, de bosses ou de dommages (visible ou cachée), notez-le sur le bond de livraison avant d'accepter la livraison et contactez Omcan dans les 24 heures qui suivent, pour que nous puissions engager une réclamation auprès du transporteur. Un rapport détaillé sur l'étendue des dommages causés à la machine doit être rempli dans un délai de trois jours, à compter de la date de livraison indiquée dans les documents d'expédition. Omcan n'a aucun droit de recours pour les produits endommagés qui ont été expédiés ou cueilli par un tiers transporteur.

General Information

Avant d'utiliser n'importe quel équipement, toujours lire et vous familiariser avec toutes les opérations et les consignes de sécurité.

Omcan voudrais vous remercier d'avoir choisi cette machine. Il est primordial de conserver ces instructions pour une référence ultérieure. Également conservez la boîte originale et l'emballage pour l'expédition de l'équipement si l'entretien ou le retour de la machine est nécessaire.

Omcan Empresa De Fabricacion Y Distribucion Inc. Y Maquinaria De Alimentos De America, Inc. dba Omcan y Omcan Inc. no son responsables de ningun daño o perjuicio causado por cualquier persona inadecuada o el uso descuidado de este equipo. El producto solo podra ser operado por una persona mayor de 18 años, en su sano juicio y no bajo alguna influencia de droga o alcohol, y que este ha sido entrenado en el correcto funcionamiento de esta máquina, y ésta usando ropa apropiada y autorizada. Cualquier modificación a la máquina anula la garantía y puede causar daños a las personas usando la máquina mientras esta en el funcionamiento.

REVISE EL PAQUETE A SU LLEGADA

Tras la recepcion de un envio Omcan favor inspeccionar daños externos. Si no hay daños evidentes en el empaque exterior, Habra el carton para asegurarse que todos los articulos solicitados estén dentro de la caja y no encuentre daños ocultos en la máquina. Si el paquete ha sufrido un manejo de poco cuidado, golpes o daños (visible o oculto) por favor anote en la factura antes de aceptar la entrega y contacte Omcan dentro de las 24 horas, de modo que podamos iniciar una reclamación con la compañía. Un informe detallado sobre los daños causados a la máquina debe ser llenado en el plazo de tres días, desde la fecha de entrega que se muestra en los documentos de envío. Omcan no tiene ningun recurso por productos dañados que se enviaron a recoger por terceros.

Antes de utilizar cualquier equipo, siempre lea y familiarizarse con todas las instrucciones de funcionamiento y seguridad.

Omcan le gustaría darle las gracias por la compra de esta máquina. Es de la mayor importancia para salvar estas instrucciones para futuras consultas. Además, guarda la caja original y el embalaje para el envío del equipo si servicio técnico o devolución de la máquina que se requiere.

Safety and Warranty

IMPORTANT SAFEGUARDS

READ ALL INSTRUCTIONS

When using, cleaning or maintaining the machine, always follow these instructions:

Safety and Warranty

IMPROPER USE

1. Do not place food in the channel and press with the plunger before you have started the machine.
2. Cleaning in a jet of water or a high pressure spray is prohibited.
3. The base must not be immersed in water.
4. Never use the appliance if the power cord is damaged. It must be replaced by either a SANTOS approved dealer or a person with similar qualifications to avoid any danger.
5. The appliance must be unplugged before any intervention on it: cleaning, general care, maintenance.
6. It is forbidden to operate the appliance on a surface with a slope in excess of 10° with respect to the horizontal plane. The feet of the machine must always be resting on this surface.
7. The use of spare parts other than certified original SANTOS parts is prohibited.
8. Never connect several appliances to the same power socket.
9. Never use the machine outdoors.
10. Never place the appliance close to or on a source of heat.
11. This appliance is a professional machine designed exclusively for professional use. It is not designed for household use.
12. This appliance is not designed for use by people (including children) whose physical, sensorial or mental capacities are impaired or by people with no experience or knowledge, unless they have been supervised or given training in the use of the appliance beforehand by a person responsible for their safety. Supervise children to ensure they do not play with the appliance.

Line protection: The appliance shall be connected only to a power 2-pole and earth socket supplied by a branch circuit of suitable voltage. The branch circuit shall have been established by a qualified electrician according to national and local codes and laws, and provided with suitable protective equipments (such as fuse, circuit breaker, etc.) as defined by these codes and laws.

CARE:

- Before connecting the machine, check that the mains electrical voltage is the same as the voltage for your appliance. Its value is shown:
 - Either on the identification plate under the machine.
 - Or on the identification plate on the last page of this manual.
- If the power cable is damaged, it must be replaced by either a SANTOS approved dealer or a person with similar qualifications to avoid any danger.

RESIDENTIAL USERS: Vendor assumes no liability for parts or labor coverage for component failure or other damages resulting from installation in non-commercial or residential applications. The right is reserved to deny shipment for residential usage; if this occurs, you will be notified as soon as possible.

1 YEAR PARTS AND LABOUR BENCH WARRANTY

Within the warranty period, contact Omcan Inc. at 1-800-465-0234 to schedule a drop off to either an Omcan authorized service depot in the area, or to an Omcan Service warehouse to repair the equipment.

Unauthorized maintenance will void the warranty. Warranty covers electrical and part failures, not

Safety and Warranty

improper use.

Please see <https://omcan.com/disclaimer> for complete info.

WARNING:

The packaging components are classified as normal solid urban waste and can therefore be disposed of without difficulty.

In any case, for suitable recycling, we suggest disposing of the products separately (differentiated waste) according to the current norms.

DO NOT DISCARD ANY PACKAGING MATERIALS IN THE ENVIRONMENT!

Technical Specifications

Model	Santos 02
Electrical	100-120V / 60Hz / 1Ph
Power	0.87 HP / 650 W
Current	5.4A
RPM	1800
Production (per Hour)	110 lbs. / 50 kgs.
Dimensions	16.5" x 10" x 14" / 420 x 250 x 360mm
Packaging Dimensions	12" x 18" x 16" / 295 x 455 x 410mm
Weight	32 lbs. / 14.5 kgs.
Packaging Weight	34 lbs. / 15.5 kgs.
Item Number	40619

Operation

RUN GRATER WITH DRY BREAD BEFORE INITIAL USE TO CLEAN IT.

USING (FIGURE 1)

1. Prepare the pieces of cheese to be grated (or the ice cubes) beforehand.
2. Make sure the drawer is correctly in place (1) (operating is servo-controlled by a safety device linked to the

drawer's presence). For the ice crusher: place the stainless steel sheet inside the drawer.

3. Start the machine by operating the On/Off button (5).
4. Lift up the lever (4), insert a piece of cheese to be grated (or ice cubes), and push on the lever steadily without forcing.
5. Repeat the above procedure as many times as necessary.
6. After use, stop the machine by operating the On/Off Button (5).

Note: removing the drawer (1) or lifting up the chute (3) stops the appliance from working (figure 6).

For easier cleaning, do not leave food to dry in the drawer or on the grating disc.

CHANGING DISC

Push the end of the lever (4), pull on the closing key (14) and remove the chute + lever unit to get to the disc (6) (figure 2).

TAKING APART (LEFT-HANDED THREAD): (FIGURE 3)

- Clamp the disc (6) and undo the screw (7) following the arrow (clockwise) with the closing key (14).

REASSEMBLING: (FIGURE 4)

- Check that the key (8) is present on the motor shaft.
- Check that the seal (13) is present on the disc (6).
- Place the disc on the motor shaft making the key match the key groove.
- Clamp the disc (6) and tighten the screw (7) following the arrow (anti-clockwise).

SAFE ACCESS TO THE TOOLS: (FIGURE 6)

The appliance can only start if the lever (4) is not extending out of the chute to insert the food (3) and if the drawer catching the food (1) is correctly placed on the slideway (2).

Removing the drawer (1) causes the machine to stop. Re-starting the appliance requires specific operation of the On / Off switch (5) again (position 1).

A cut in the mains power supply results in the On / Off switch (5) stopping (position 0).

The fact of lifting the lever to add food into the chute (3) causes the motor to stop, without causing the appliance to stop completely.

Lowering the lever (4) allows the motor to be restarted.

Operation

MOTOR OVERLOAD SAFETY FEATURE:

Should the motor become blocked (foreign body, object that is too hard, too much pressure with the lever on the products being processed), the On / Off switch (5) automatically trips to the 0 position.

Correct the problem and press the On / Off switch (5) (position 1).

If the problem persists, switch off the power supply to the machine (unplug the cord from the mains socket) and call in the maintenance service or contact a SANTOS approved dealer.

Maintenance

Before carrying out any work on the appliance, it must in all cases be unplugged from the mains power supply and the motor start capacitor discharged.

DISCHARGING THE CAPACITOR

Use a screwdriver with insulated handle to touch the 2 connectors on the capacitor (12). The appearance of an electric arc shows that the capacitor has discharged.

SPARE PARTS

IMPORTANT: Use of spare parts other than certified original SANTOS parts is prohibited.

This machine requires no specific maintenance. The bearings are lubricated for life. If work is required to replace worn parts such as start relay or the electric or other components, refer to the parts list.

For all spare part orders (see references in the exploded view at the end of the manual), state:

- The type.
- The machine serial number.
- The electrical specifications recorded under the machine.

The complete disc (6) can be considered to be a part subject to wear.

For the machine to operate properly, it is recommended that a check is also made that the seal (13) is in good condition, in particular the absence of any signs of tearing of the lip.

CLEANING

The appliance should neither be cleaned in a jet of water nor with a high pressure spray.

1. Put the appliance on stop position by pushing the On/Off button and disconnect the plug.

Maintenance

2. Remove the chute + lever assembly and the grating disk.
3. Wash the chute + lever assembly, the grating disc and the drawer with washing-up detergent, rinse, dry and reassemble the unit.
4. The frame is to be sponged clean then dried. Polish from time to time with a non-abrasive product for windows or a cleaning agent for metal.

Troubleshooting

Identifying the cause of appliance stoppage precisely.

THE APPLIANCE DOES NOT START: (FIGURE 6)

- Check: the mains supply, the condition of the supply cord.
- Check: the position of the drawer (1) on its slideway (2), the position of the lever (4) (no more than 2 cm outside the chute (3)).

THE APPLIANCE STOPS FURTHER TO AN OVERLOAD:

See the chapter “motor overload safety feature”.

Figure Drawings

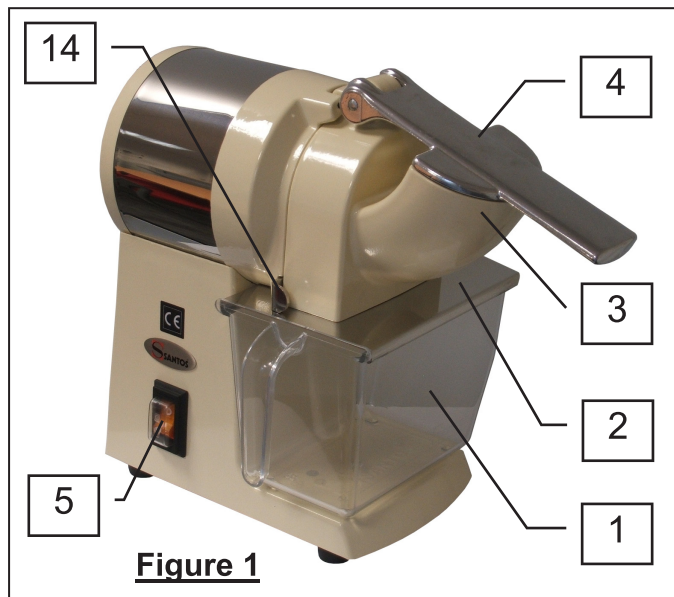
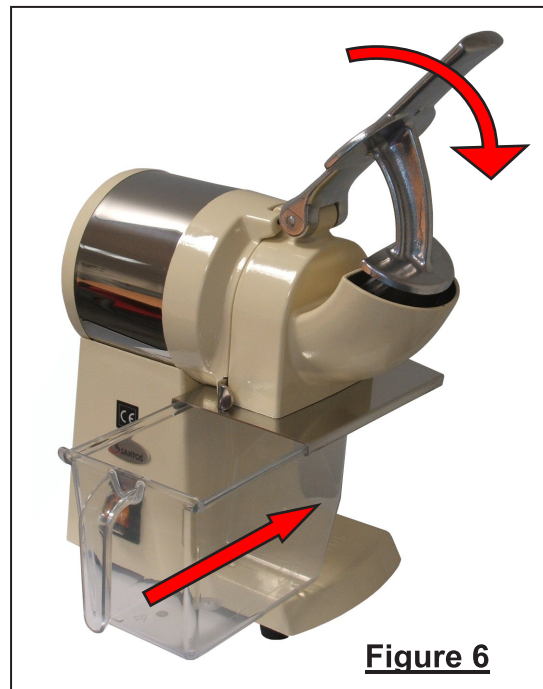
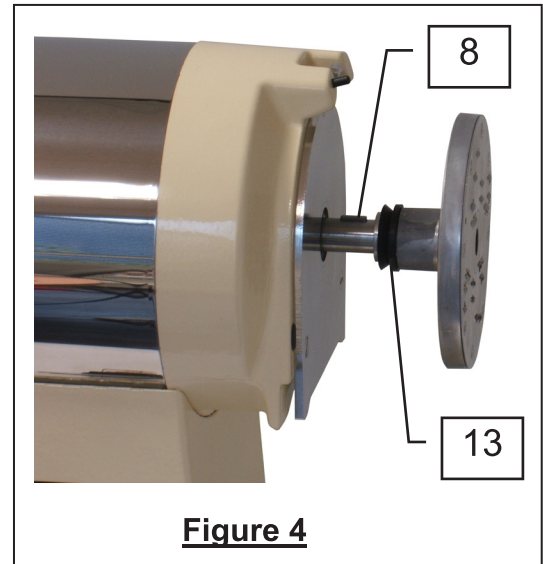
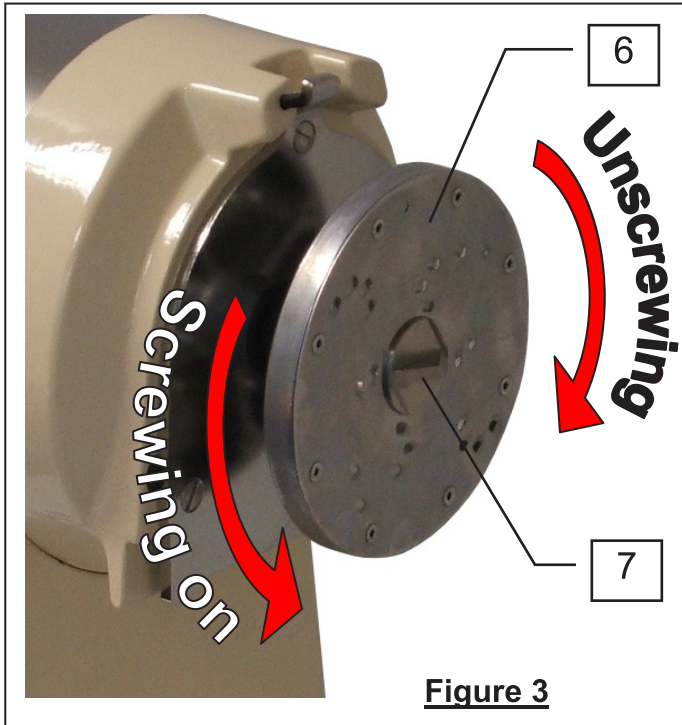
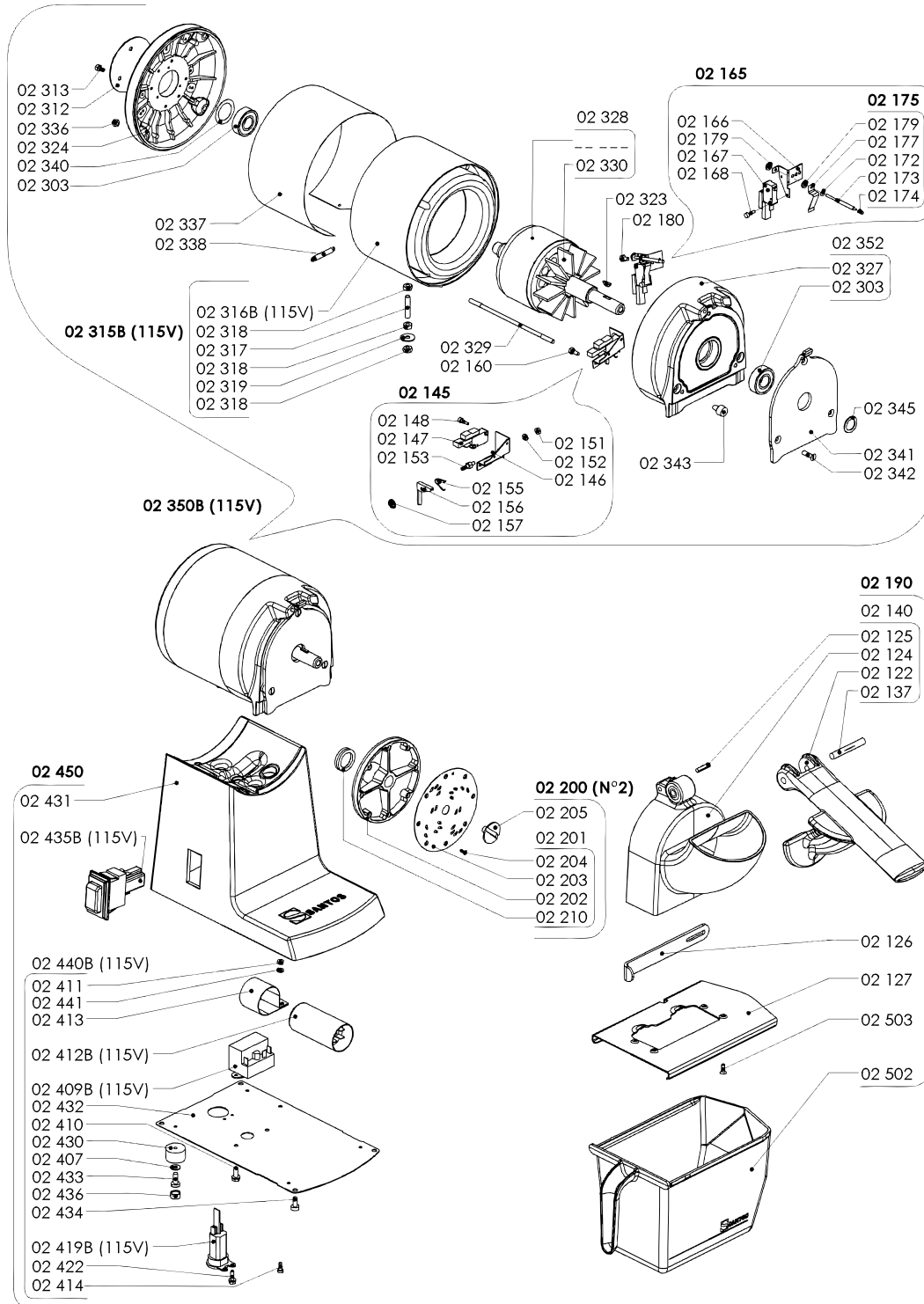

Figure Drawings



Parts Breakdown

Model Santos 02 40619



Parts Breakdown

Model Santos 02 40619

Item No.	Description	Position	Item No.	Description	Position	Item No.	Description	Position
73603	Aluminum Lever for 40619	02122	73632	Complete Grater Housing for 40619	02190	73657	Motor Protector Spring for 40619	02338
73604	Grater Housing for 40619	02124	73633	Complete Grating Disc 3mm with Screw for 40619	02200	73658	Ondulated Washer 6202 for 40619	02340
73605	Grooved Pin 5x22 for 40619	02125	40950	Grating Disc Complete Assembly - 2mm Holes for 40619	02201AD	73659	Flange for 40619	02341
73606	Locking Key for 40619	02126	40951	Grating Disc Complete Assembly - 3mm Holes for 40619	02201BD	73660	Screw FS M5x16 Stainless Steel for 40619	02342
73607	Drawer Sustainer for 40619	02127	40952	Grating Disc Complete Assembly - 4mm Holes for 40619	02201CD	73661	Rubber Foot D 12x7.5 for 40619	02343
73608	Grooved Pin 8x55 for 40619	02137	40953	Grating Disc Complete Assembly - 6mm Holes for 40619	02201DD	73662	Disc Washer for 40619	02345
73609	Complete Grater Housing for 40619	02140	40954	Grating Disc Complete Assembly - 8mm Holes for 40619	02201ED	73664	Complete Motor Single Phase 110-120V 60Hz for 40619	02350B
73610	Detection Assembly for Drawer for 40619	02145	40955	Grating Disc Complete Assembly - Parmesan for 40619	02201FD	73665	Complete Front Flange for 40619	02352
73611	Drawer Contact Switch Holder for 40619	02146	40956	Grating Disc Complete Assembly - Fondue for 40619	02201GD	AC420	Complete Rotor with Fan for 40619	02361
73612	Micro Switch for 40619	02147	40665	Locking Screw for 40619	02205	AC421	Fan for 40619	02363
73613	Screw for 40619	02148	73637	V Ring Gasket V22 for 40619	02210	AC422	Complete Stator Winding 110V 60Hz for 40619	02365B
AC413	Washer D3 for 40619	02149	73639	Bearing 6202 for 40619	02303	AC423	Stator Only Single Phase 110V 60Hz for 40619	02366B
73614	Nut H M4 Zn for 40619	02151	AC415	Bearing Washer for 40619	02304	AC424	Complete Bottom Plate 220V 50Hz for 40619	02402
73615	Washer AZ 4 for 40619	02152	73640	Chromed Bearing Washer for 40619	02312	AC425	Bottom Plate Only (Old) for 40619	02403
73616	Safety Lever for 40619	02153	73641	Screw H 4x10 for 40619	02313	AC426	Rubber Foot D 22x10 for 40619	02406
AC414	Washer 4x14 Zn for 40619	02154	AC416	Bearing 6202 for 40619	02314	73666	Washer 5x12 for 40619	02407
73617	Safety Lever Spring for 40619	02155	73643	Complete Stator (Winding) 110V 60Hz (or 220V 60Hz) for 40619	02315B	73668	Starting Relay 100-120V 50/60HZ and 220-240V 60Hz for 40619	02409B
73618	Safety Lever for 40619	02156	73645	Stator only 1 Phase 110V 60Hz (or 220V 60Hz) for 40619	02316B	73669	Screw CB M4x10 Zn for 40619	02410
73619	Washer for 40619	02157	73646	Rod M6x35 for 40619	02317	73670	Nut H M4 Zn for 40619	02411
73620	Screw 4x8 Zn Auto for 40619	02160	73647	Nut H M6 Zn for 40619	02318	73672	Capacitor 250 MF 100-120V 50/60Hz for 40619	02412B
73621	Holding Assembly for Lever Safety Detection for 40619	02165	73648	Washer 6x18 for 40619	02319	73673	Capacitor Ring for 40619	02413
73622	Microswitch Holding Plate for 40619	02166	73649	Pin 3x5 for 40619	02323	73674	Screw CB M4x20 Zn for 40619	02414
73623	Micro Switch for 40619	02167	73650	Rear Flange for 40619	02324	73676	Power Cord with USA Plug for 40619	02419B
73624	Screw for 40619	02168	73651	Front Flange for 40619	02327	73677	Screw H 4.2x12.7 Zn Auto for 40619	02422
73625	Washer for 40619	02172	73653	Assembling Threaded Rod M5x147 for 40619	02329	73678	Rubber Foot D25x15 for 40619	02430
73626	Lever Safety Detection Axle for 40619	02173	73654	Fan for 40619	02330	73679	Painted Base Only for 40619	02431
73627	Detection Pin End for 40619	02174	AC417	Screw CB M4x10 Zn (Old) for 40619	02332	73680	Bottom Plate for 40619	02432
73628	Lever Detection Assembly for 40619	02175	AC418	Spacer D 16x20x35 (Before 2009) for 40619	02334	73681	Screw CBLZ 5.5x16 for 40619	02433
73629	Safety Spring Plate for 40619	02177	AC419	Assembling Threaded Rod M5 for 40619	02335	73682	Screw H M5x12 Zn Autotar for 40619	02434
73630	Washer for 40619	02179	73655	Cap Nut H M5 Zn for 40619	02336	73684	Special On-Off Multifunction Switch D855 8A115V for 40619	02435B
73631	Screw 4X8 Zn Auto for 40619	02180	73656	Stainless Steel Motor Protector for 40619	02337	73685	Cap D12.2x6.2 Black for 40619	02436

Parts Breakdown

Model Santos 02 40619

Item No.	Description	Position	Item No.	Description	Position	Item No.	Description	Position
AC427	Membrane + Plastic Tally Assembly for 40619	02437	AC428	Capacitor 150 µF Diam 46 for 40619	02447	40667	Grater Drawer for 40619	02502
73687	Complete Bottom Plate 110V for 40619	02440B	AC429	Capacitor Ring D46 for 40619	02448	73691	Screw FS M4x10 Stainless Steel for 40619	02503
73688	Washer AZ 4 Zn for 40619	02441	AC430	Complete Base 120V 60Hz for 40619	02450B	AC431	Special Key for Cheese Grater (Before 2009) for 40619	02901

Electrical Schematics

Model Santos 02 40619

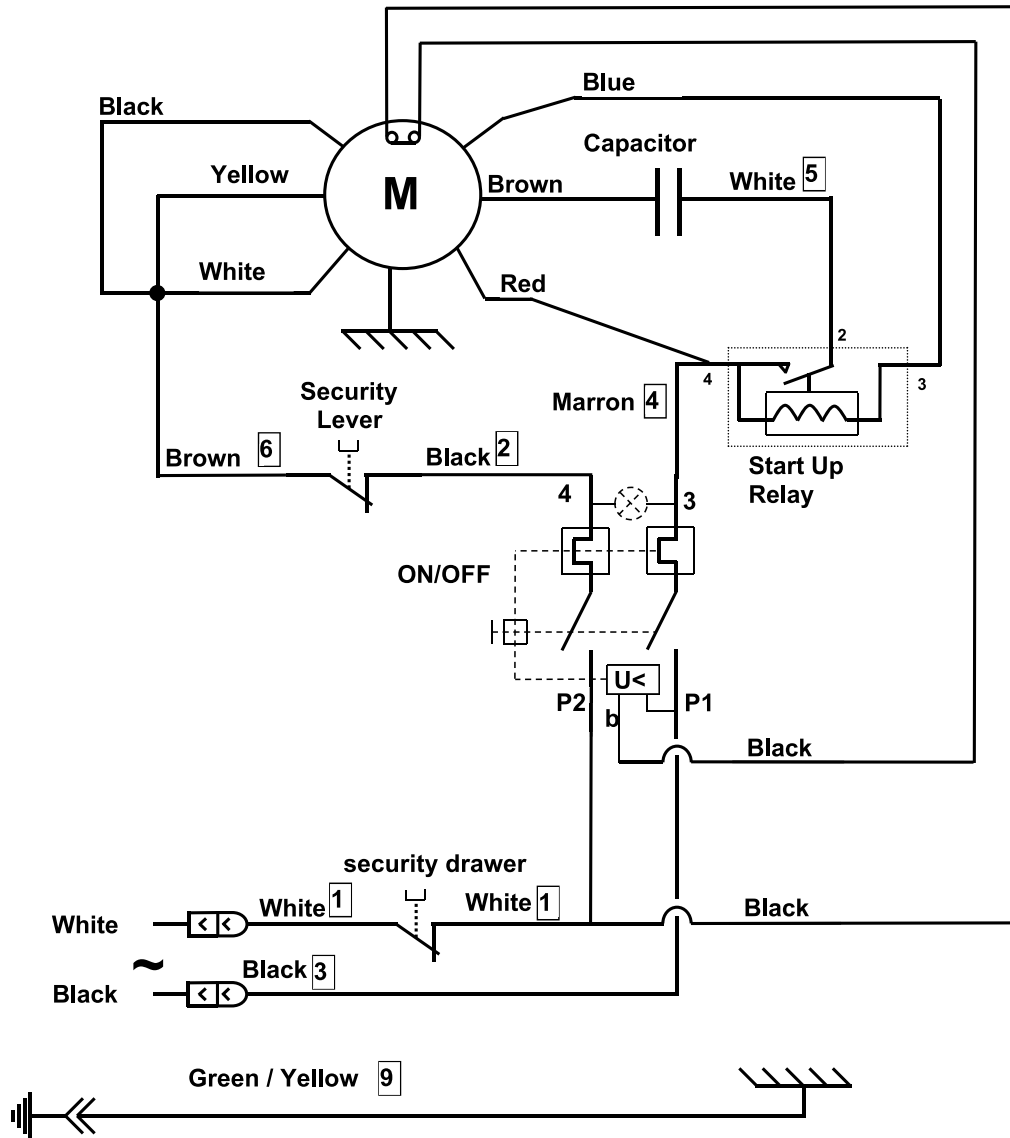

No.	Description	No.	Description
1	Drawer.	5	On-off switch.
2	Slideway.	6	Complete disc.
3	Chute.	9	Fastening screw.
4	Lever.		



Warranty Registration

Thank you for purchasing an Omcan product. To register your warranty for this product, complete the information below, tear off the card at the perforation and then send to the address specified below. You can also register online by visiting:

Merci d'avoir acheté un produit Omcan. Pour enregistrer votre garantie pour ce produit, complétez les informations ci-dessous, détachez la carte au niveau de la perforation, puis l'envoyer à l'adresse spécifiée ci-dessous. Vous pouvez également vous inscrire en ligne en visitant:

Gracias por comprar un producto Omcan usted. Para registrar su garantía para este producto, complete la información a continuación, cortar la tarjeta en la perforación y luego enviarlo a la dirección indicada a continuación. También puede registrarse en línea en:

<https://omcan.com/warranty-registration/>

For mailing in Canada

Pour postale au Canada

Por correo en Canadá

OMCAN

PRODUCT WARRANTY REGISTRATION

3115 Pepper Mill Court,

Mississauga, Ontario

Canada, L5L 4X5

For mailing in the US

Pour diffusion aux États-Unis

Por correo en los EE.UU.

OMCAN

PRODUCT WARRANTY REGISTRATION

4450 Witmer Industrial Estates, Unit 4,

Niagara Falls, New York

USA, 14305

or email to: service@omcan.com



Purchaser's Information

Name: _____

Address: _____

City: _____ Province or State: _____ Postal or Zip: _____

Country: _____

Dealer from which Purchased: _____

Dealer City: _____ Dealer Province or State: _____

Invoice: _____

Model Name: _____ Model Number: _____

Machine Description: _____

Date of Purchase (MM/DD/YYYY): _____

Would you like to extend the warranty? Yes No

Company Name: _____

Telephone: _____

Email Address: _____

Type of Company:

Restaurant Bakery Deli

Butcher Supermarket Caterer

Institution (specify): _____

Other (specify): _____

Serial Number: _____

Date of Installation (MM/DD/YYYY): _____

Thank you for choosing Omcan | Merci d'avoir choisi Omcan | Gracias por elegir Omcan



Since 1951 Omcan has grown to become a leading distributor of equipment and supplies to the North American food service industry. Our success over these many years can be attributed to our commitment to strengthen and develop new and existing relationships with our valued customers and manufacturers. Today with partners in North America, Europe, Asia and South America, we continually work to improve and grow the company. We strive to offer customers exceptional value through our qualified local sales and service representatives who provide convenient access to over 5,000 globally sourced products.

Depuis 1951 Omcan a grandi pour devenir un des “leaders” de la distribution des équipements et matériel pour l’industrie des services alimentaires en Amérique du Nord. Notre succès au cours de ces nombreuses années peut être attribué à notre engagement à renforcer et à développer de nouvelles et existantes relations avec nos clients et les fabricants de valeur. Aujourd’hui avec des partenaires en Amérique du Nord, Europe, Asie et Amérique du Sud, nous travaillons continuellement à améliorer et développer l’entreprise. Nous nous efforçons d’offrir à nos clients une valeur exceptionnelle grâce à nos ventes locales qualifiées et des représentants de service qui offrent un accès facile à plus de 5000 produits provenant du monde entier.

Desde 1951 Omcan ha crecido hasta convertirse en un líder en la distribución de equipos y suministros de alimentos en América del Norte industria de servicios. Nuestro éxito en estos años se puede atribuir a nuestro compromiso de fortalecer y desarrollar nuevas relaciones existentes con nuestros valiosos clientes y fabricantes. Hoy con socios de América del Norte, Europa, Asia y América del Sur, que trabajan continuamente para mejorar y crecer la empresa. Nos esforzamos por ofrecer a nuestros clientes valor excepcional a través de nuestro local de ventas y representantes de los servicios que proporcionan un fácil acceso a más de 5,000 productos con origen a nivel mundial.

